

CITY OF WINNEMUCCA  
PUBLIC WORKS MANUAL

**SECTION "B"**  
**STORM DRAIN SYSTEM IMPROVEMENTS**

**CITY OF WINNEMUCCA PUBLIC WORKS MANUAL**  
**SECTION B: STORM DRAIN IMPROVEMENTS**

General Notes:

1) All construction shall be in conformance with the latest edition of the "Standard Specifications for Public Works Construction" (commonly referred to as the "orange book"), and the "Standard Details for Public Works Construction" as published by Washoe County RTC (et al) unless specifically modified in writing by the City.

2) Listed below are some of the more common requirements/specifications used on storm drain projects for easy reference by the public, developers and contractors:

**Trench Excavation and Backfill:**

Materials: Refer to Section 200.03 of the Standard Specifications.

Construction: Refer to Section 305 of the Standard Specs.

Maximum backfill lift shall be 12 inches.

Required compaction in streets: 95 %.

Concrete Slurry required on all collector streets (see Section 202.02).

**Storm Drain Pipe:**

Materials: Refer to Section 203 of the Standard Specs:

Corrugated Metal Pipe: 10 or 12 gauge conforming to AASHTO M-36 and M-218. Coupling bands conforming to AASHTO M-36 and galvanized bolts conforming to AASHTO A-307 and A-164 Type RS (or A-165 type TS).

Reinforced Concrete Pipe: Class III tongue and groove type conforming to ASTM C-76 and C-655.

Corrugated Polyethylene Pipe: Must conform to AASHTO M-294 and ASTM F-667. Couplings and fittings must conform to AASHTO 294-851.

Construction: Refer to Section 306 of the Standard Specs:

Sand pipe bedding may be required by the City Engineer where native material is unsatisfactory. Trench backfill must be compacted to 95% of maximum dry density. All trenches shall satisfy current OSHA standards.

**Drop Inlets:**

Materials: Refer to Section 204.03 of the Standard Specs.

Construction: Refer to Section 204.02 of the Standard Specs:

Type 4-R unless specifically approved by the City Engineer.

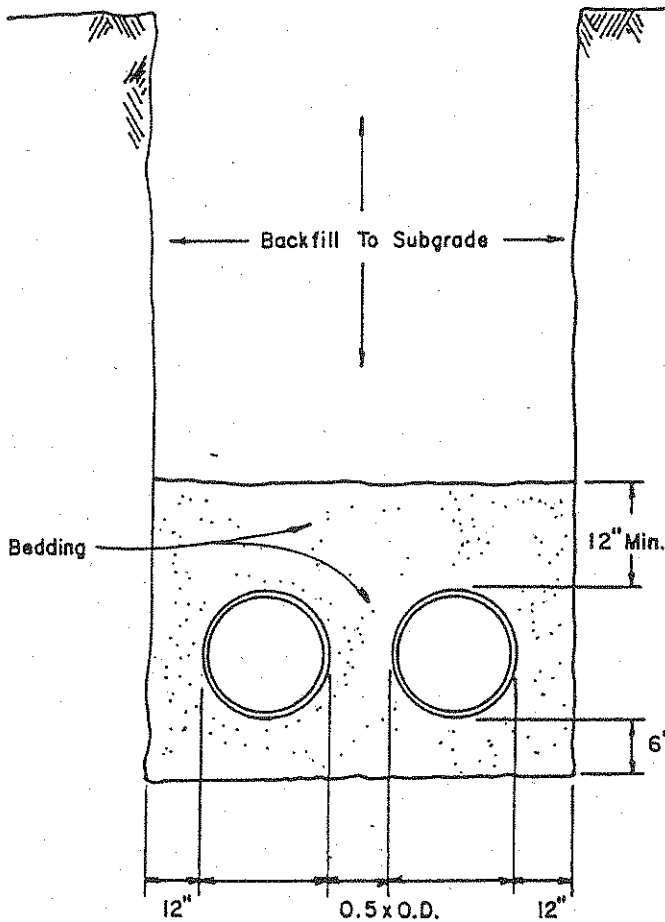
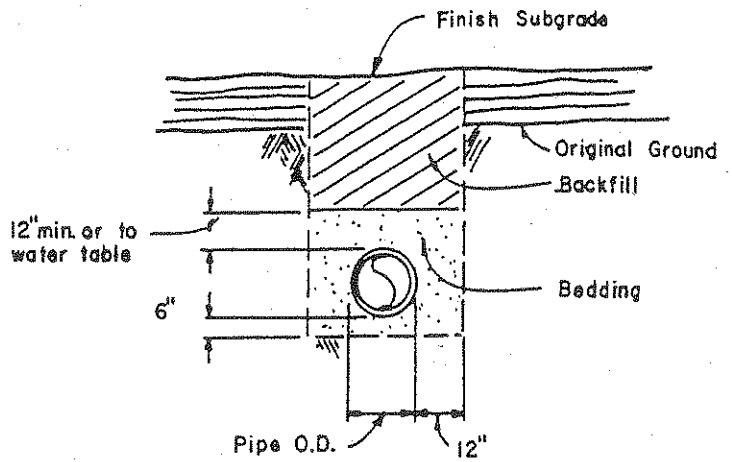
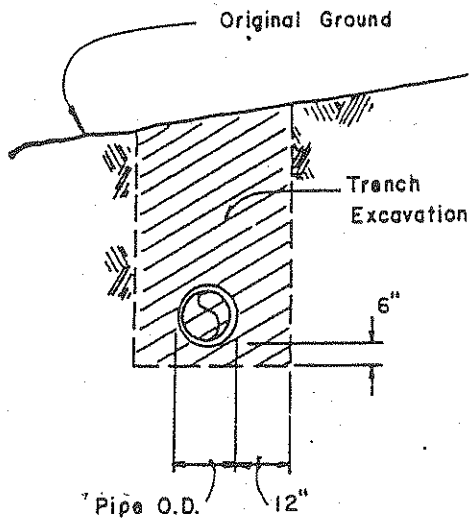

**GENERAL NOTES:**

- 1.) Water densified backfill and tunneling shall be by special provision only.
- 2.) Backfill shall meet the requirements for Class "E" backfill with no rocks over 4" compacted in 6" (max.) lifts to min. 95% of max. dry density.
- 3.) Bedding Material shall meet requirements for Class "A" Backfill as shown in subsection 200.03.02 of Standard Specifications or as specified by the Agency and shall be compacted to at least 95% of max. dry density.
- 4.) For trenches in roadway section, see trench patch details See Dwg. No. 1-16
- 5.) For the purpose of payment, excavation and backfill quantities are based on these standard drawings, and no additional compensation will be made. Shoring or sloped cut slopes may be necessary, but there will be no additional payment. All excavations shall conform to the latest O.S.H.A. - requirements.
- 6.) Not for use in City of Reno. Refer to Dwg. R-24.
- 7.) Place metallic location tape 1 ft. above water pipe, Carson City.

NO. REVISION DATE			STANDARD DETAILS FOR PUBLIC WORKS CONSTRUCTION		SECTION	
1	Note 6	6-95	<h1 style="margin: 0;">TRENCH EXCAVATION AND BACKFILL</h1>		2	
					DRAWING NO. 2-1 (305)	
					DATE 7-81	PAGE 1

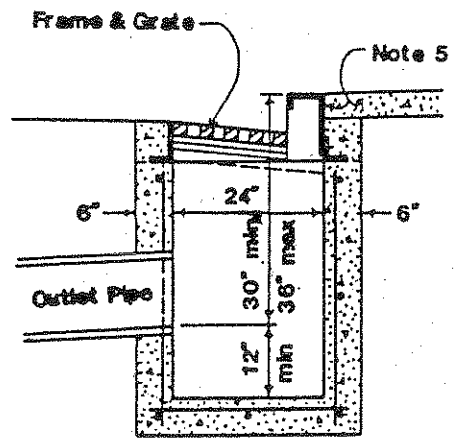
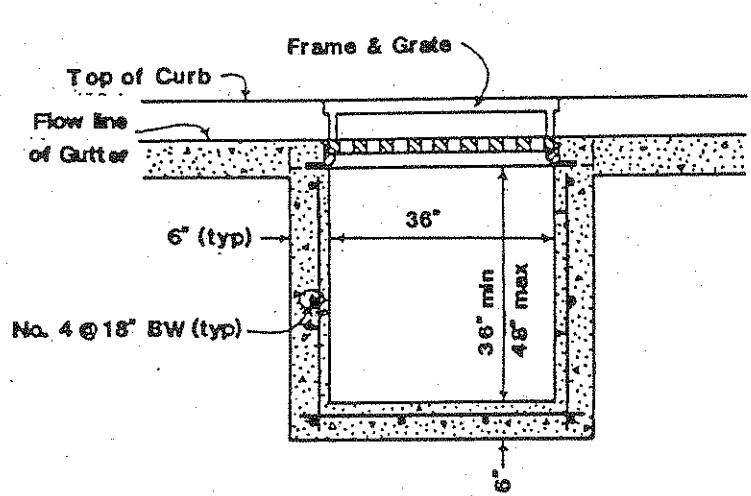
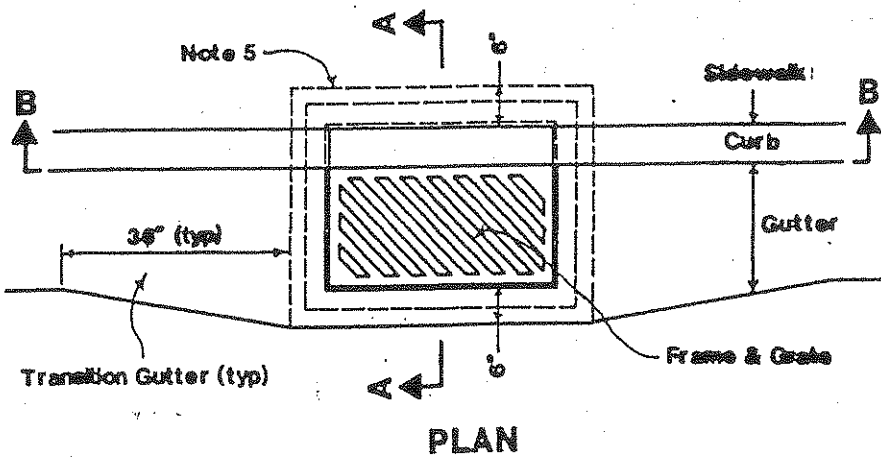

- NOTES:**
1. Concrete shall be Class AA or DA Portland cement concrete.
  2. Reinforcing steel shall be Grade 40 steel and have 1.5" clear cover.
  3. Concrete structure may be a pre-cast concrete unit upon approval of the City Engineer. Base of pre-cast concrete unit shall be placed on 3" fresh concrete. *where required by City Engineer.*
  4. Frame and grate shall be Keenah R-3067 or approved equal.
  5. Concrete shall be placed as shown when not located in a sidewalk.

NO.	REVISION	DATE	STANDARD DETAILS FOR PUBLIC WORKS CONSTRUCTION	SECTION WINNEMUCCA	
			<b>CATCH BASIN TYPE 4-R</b>	DRAWING NO. WN - 5	
				DATE 3 - 91	PAGE 6